

# 20/00464/FUL

Hybrid planning application seeking;

1. Full planning permission for the erection of a B2 unit (general industrial) with associated landscaping, access and parking.
2. Outline planning permission (all matters reserved except access) for a mix of B1, B2 and B8 use classes (employment).

Part Parcel 3152, Tewkesbury Road, Deerhurst, Gloucester,  
Gloucestershire

# Site Location Plan



# Aerial View

Application Site



# Proposed Site Layout Plan



# Proposed Street Scene Plans

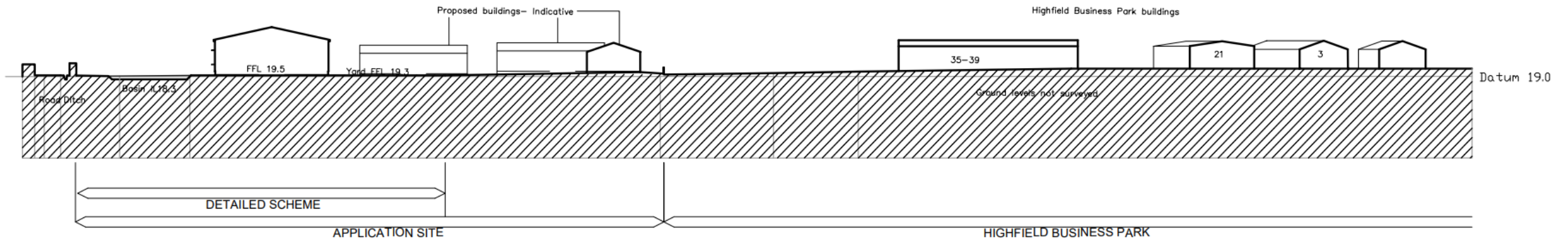

# Proposed Elevations

CLIENT, WE ACCEPT NO RES  
AS DUTY HOLDER UNDER CI

SIGNAGE IS INDICATIVE- SL  
SEPARATE ADVERTISEMENT



SOUTH ELEVATION

REVISIONS:



WEST ELEVATION

## PLANNI



Architectu

T 01905 821816 M 0  
HJIArchitectureLtd@

Client:  
H. Wolton

Project:  
Land adjacent to  
Cursey Lane

Title:  
Elevations  
Sheet 1

# Proposed Floor Plans

